

INOX | Upright Cabinets

BAKERY REFRIGERATED CABINETS ▶ VENTILATED ▶ FREEZER

QPN 1640



- R290
- 75 mm
- 4 CLIMATIC CLASS 38°C
- LED
-
-

DETAILS

- The items can be supplied either with adjustable feet or lockable castor
- Euronorm 600x400mm set of guides (10 Layer for each door)
- Curved edge for easy cleaning
- Evaporator with anti-corrosion treatment
- Digital control and white backlit main switch



GENERAL FEATURES

- EURONORM Freezer upright cabinet
- Stainless Steel exterior and interior
- Ventilated Cooling
- Automatic defrost with electric heater
- Evaporator with anti-corrosion treatment
- Engine made with "Cassette system"
- Foaming Agent Cyclopentane (75mm per side)
- Digital Thermostat
- White backlit main switch
- Opening door alarm
- Removable Gasket
- LED light and lock fitted as standard
- Door with self closing door
- Set of 20 slides for bakery tray 600X400
- N.4 S/S Adjustable feet - (Lockable castor as Optional)
- Energy efficiency class: F

TECHNICAL SPECIFICATIONS

Capacity	1300 L
Temperature	-18° ~ -22°C
Consumption	14.8 kWh/24h
Rated Power	750 W
Noise level	53 dB(A)
Net Weight	197 Kg
Gross Weight	220 Kg
External Dimensions (WxDxH mm)	1400x820x2050
Internal Dimensions (WxDxH mm)	1250x685x1435
Packaging dimensions (WxDxH mm)	1440x860x2080
Loading quantities 20'/40'/40'HQ	10/21/21

PRODUCT DIMENSIONS

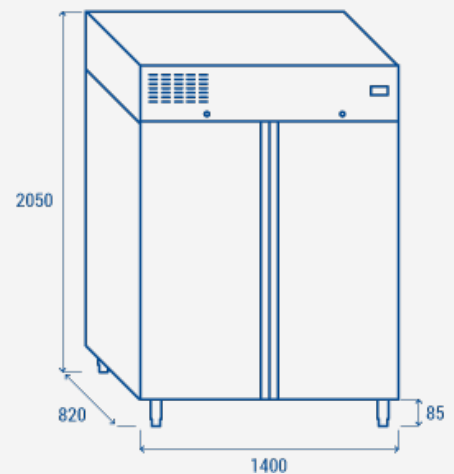

CERTIFICATION

CE RoHS

